

BenchTOF

The next generation of time-of-flight
mass spectrometers for GC and GC×GC

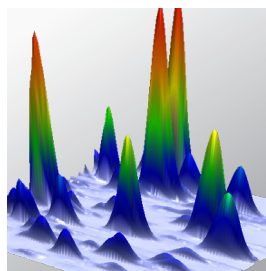

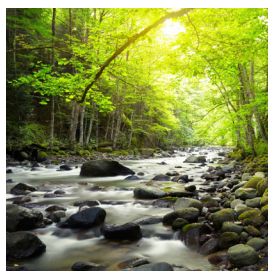

A BenchTOF for every application...

Outstanding performance for every GC and GC×GC application, unbeatable productivity and enhanced quality of results come as standard with every BenchTOF.



Take the next step up in GC-MS and harness the SIM-level sensitivity and full spectral information available with **BenchTOF-Evolve™**, while keeping the user interface you're familiar with.

If you're in a high-throughput or QA/QC laboratory, **BenchTOF-HD™** with TOF-DS™ software gives you the outstanding productivity you need, whatever your GC (or GC×GC) application.

If you'd love the extra confidence in sample characterisation that comes with Tandem Ionisation®, then choose **BenchTOF-Select™**.

Join the growing number of laboratories worldwide, and discover what BenchTOF can bring to your analysis.

Delivering unparalleled confidence for sample characterisation

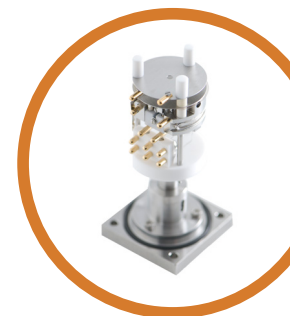

High-definition TOF MS

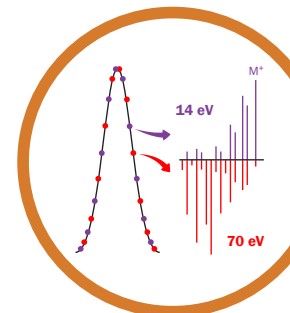

Tandem Ionisation

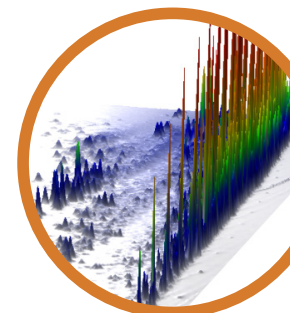

GC×GC solutions

Innovative technology, unique design

The unique design of BenchTOF opens up possibilities that cannot be achieved with other GC-MS techniques.

BenchTOF instruments incorporate the latest advances in mass spectrometry, including **Tandem Ionisation** for confident identification and unparalleled productivity.

Additionally, novel software developments, including the **ChromSpace**® GC×GC data-processing module for BenchTOF, enable simple workflows for evolving your laboratory's capabilities.

The combination of these advances, with the inherent sensitivity and spectral quality of BenchTOF, delivers the analytical resolution required to tackle even the most challenging analyses.



Tandem Ionisation

Markes' patented* Select-eV® technology allows you to collect soft EI spectra down to 10 eV, with no inherent loss in sensitivity and full automation in TOF-DS software with no need for manual intervention.

Tandem Ionisation® now adds unparalleled productivity for soft ionisation. Soft and hard ionisation spectra are obtained across every peak, in both GC and GC×GC analyses, for comprehensive sample characterisation in a single run.

* US Patent No. 9,524,858.

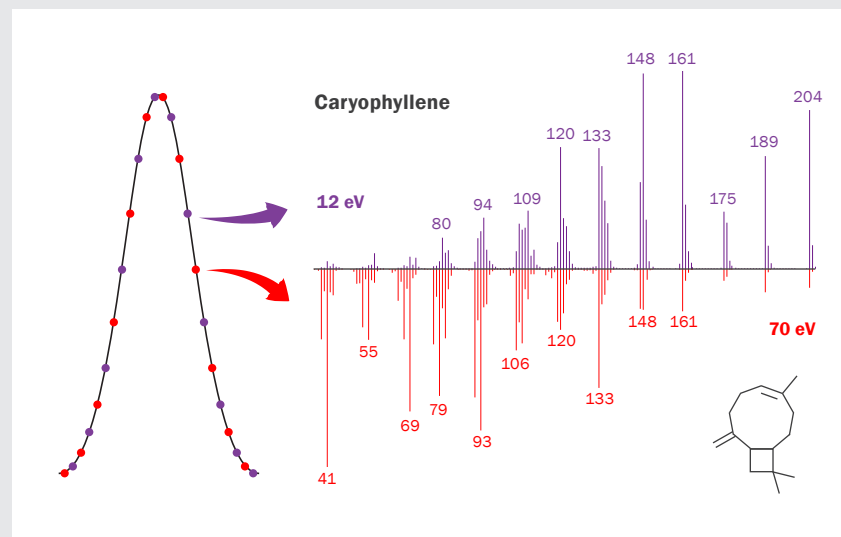

One chromatographic peak, two complementary spectra. Rapid switching of ionisation energy enables reference-quality 70 eV and soft EI spectra to be obtained simultaneously, without user intervention and in a single workflow.

“The combination of GC×GC and mass spectra at low and high ionisation energies confers unparalleled power to identify specific isomers within our chromatograms”

Dr M. Salim Alam

School of Geography, Earth and Environmental Sciences, University of Birmingham, UK



High-definition TOF MS

Changing the way you think about TOF MS

Every BenchTOF instrument offers an unbeatable combination of sensitivity, spectral quality, selectivity, speed and stability, which together deliver 'high-definition' mass spectrometry – a powerful approach to any GC–MS or GC×GC–MS application.

Outstanding sensitivity

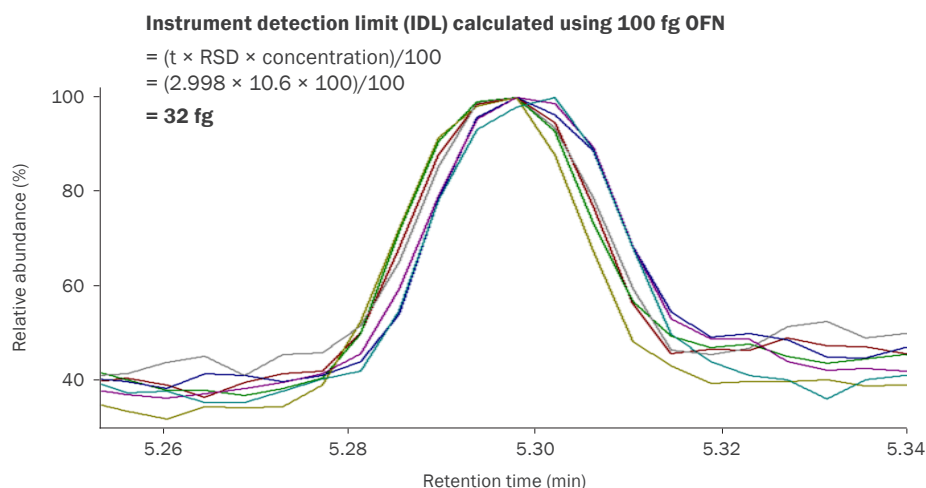

Outstanding results for trace-level analysis of targets and unknowns are possible with BenchTOF. Time-of-flight instruments are not mass filters and simultaneously analyse all ions. When combined with the highly efficient direct extraction ion source in BenchTOF, this boosts sensitivity to the level normally encountered in selected ion monitoring (SIM) mode – as illustrated by the calculated IDL from repeat injections of octafluoronaphthalene (OFN).

Confident identification

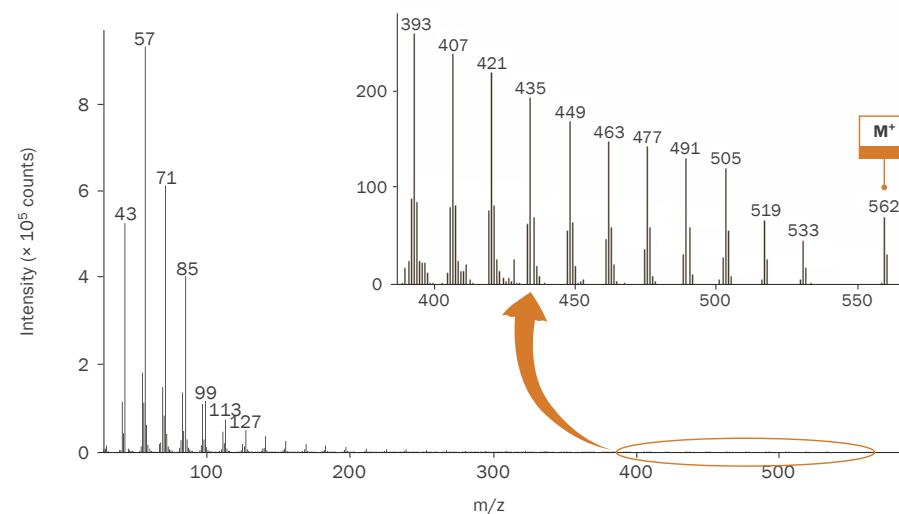

Unlike other TOF mass spectrometers, the spectral quality of BenchTOF results in excellent matches to 'classical' quadrupole spectra in commercial or custom libraries. In this example, the spectrum of tetracontane ($\text{C}_{40}\text{H}_{82}$) shows preservation of the molecular ion.

Enhanced data clarity

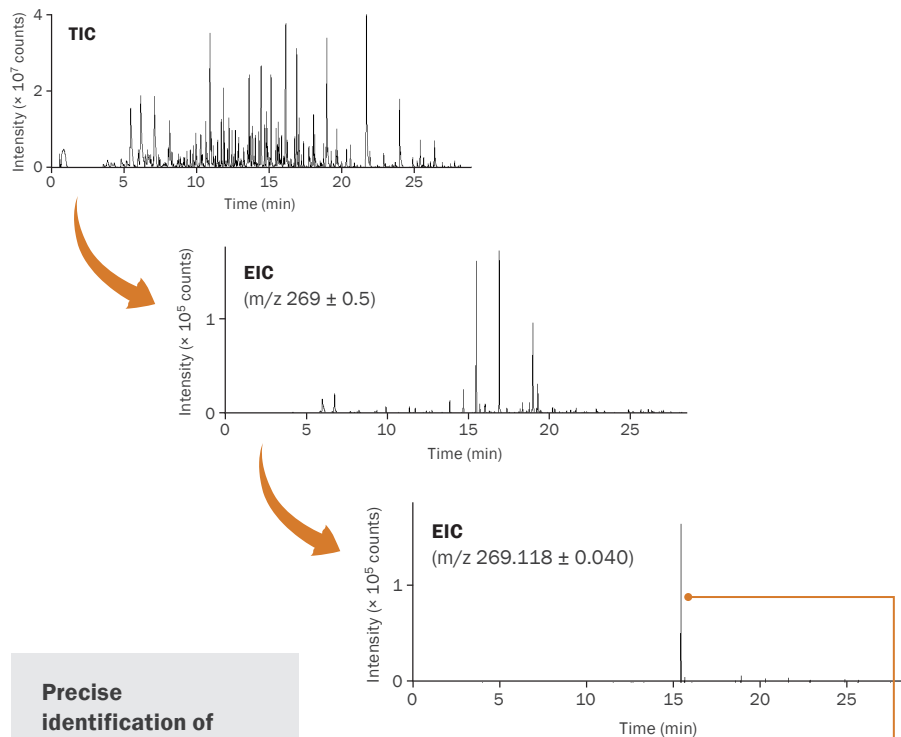

Precise identification of target compounds becomes possible

when sub-unit mass selectivity is used to eliminate matrix interferences – as illustrated here for identification of the herbicide alachlor in a river water extract. Signal-to-noise ratios are also dramatically improved, enhancing quantitation of trace-level analytes in complex matrices.

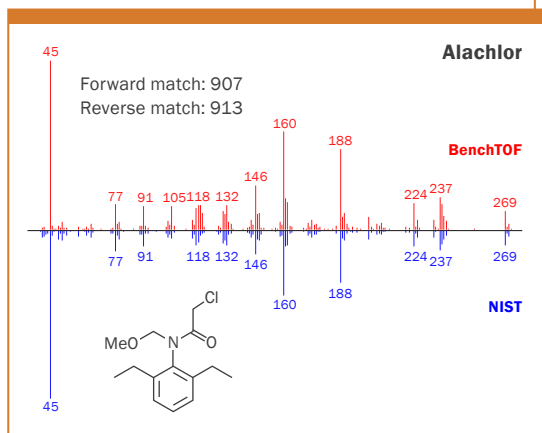

Flexibility for fast GC and GC×GC

High-speed spectral acquisition

provides information-rich datasets – which allow enhanced data-mining, and ensure compatibility with fast GC and GC×GC. The transition to GC×GC is now even easier with the ChromSpace data processing plug-in for TOF-DS.

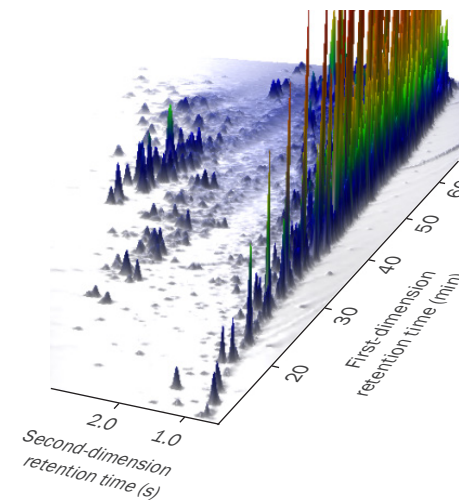

Minimal maintenance

The exceptional stability of BenchTOF

reduces the need for maintenance, minimising downtime and improving productivity – as demonstrated here by the relative standard deviations obtained over the course of a month for a fragrance mix. Even with no intermediate instrument tuning, the ISTD-corrected area responses for 213 injections show minimal variation.

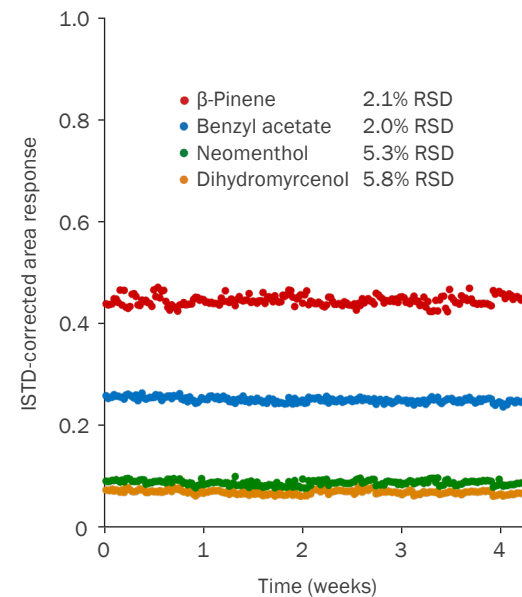



BenchTOF-Evolve™

A stepping-stone to time-of-flight mass spectrometry.

For laboratories attuned to routine GC-MS workflows, BenchTOF-Evolve provides a refreshingly straightforward way of realising the benefits of TOF mass spectrometry. The software package that comes with BenchTOF-Evolve provides full instrument control, but minimises any training requirements by allowing you to process the data in your familiar software environment. Also supplied as standard is Markes' TargetView™ platform for powerful peak deconvolution and compound identification in challenging samples.

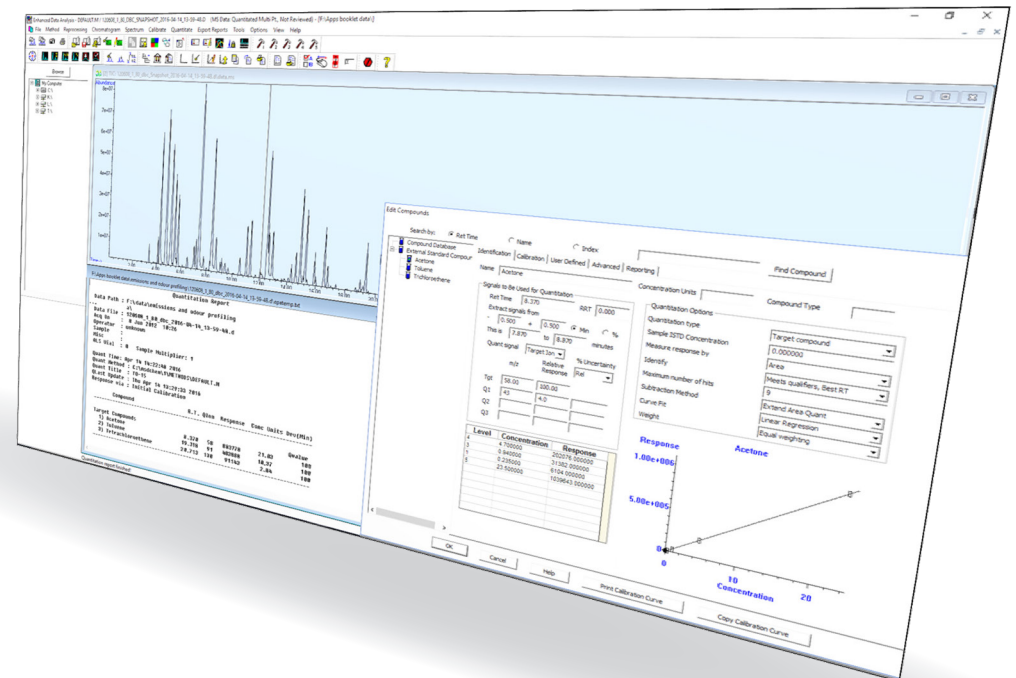
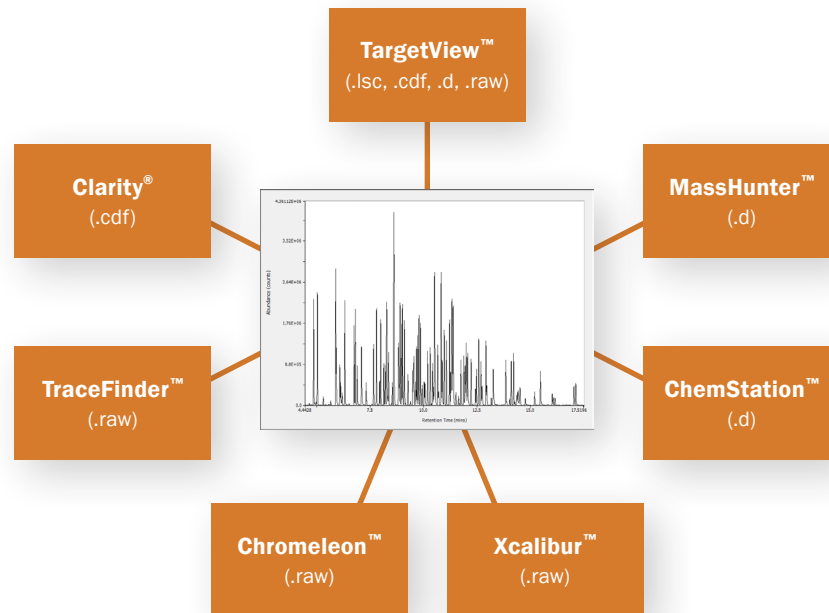

Familiar data-processing protocols – such as Agilent's ChemStation™ package (shown here) – can be used to analyse data generated by BenchTOF-Evolve, thanks to the ability to save data files in a range of file formats. BenchTOF-Evolve also fits seamlessly into any laboratory, delivering enhanced data confidence with no impact on workflows.

Powerful features for improved laboratory workflow

The needs of demanding high-throughput laboratories are exceeded, thanks to the TOF-DS™ software package that comes as standard with every BenchTOF-HD and BenchTOF-Select. In addition to full instrument control, you'll be able to enjoy the benefits of automated, real-time data-processing with immediate display and reporting of results and unlockable parameters for fast sequencing and rapid method development. Large-scale data screening and comparison of complex GC-MS profiles is also simplified with the innovative ChromCompare® module.

An icon-based method overview in TOF-DS makes setup easy.



Real-time data processing

Auto-propagating peak tables

With real-time data processing, automated integration, deconvolution and library-searching can all be set to happen while the sample is still acquiring.



The fast qual-to-quant workflow in TOF-DS makes it easy to import target compounds, quant ions and retention time windows from a spreadsheet.

The results browser shows all the quantitative information on one screen – including compound list, sample list, calibration curve and graphics for the identified peak and associated internal standard (such as EIC overlays and spectra).

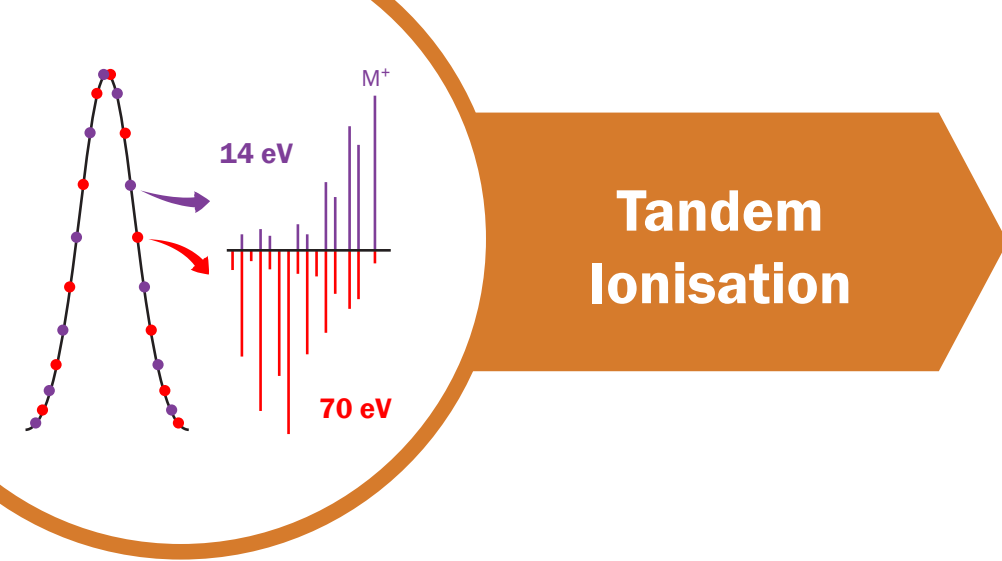

Tandem Ionisation

A ground-breaking advance in MS

Tandem Ionisation[®] adds to the already innovative technology featured in all BenchTOF instruments, by incorporating a novel ion-source design for simultaneous collection of hard and soft EI spectra. With Tandem Ionisation you can enjoy effortless real-time visualisation of results within TOF-DS software, improved detection limits and additional confidence in compound identification using qualifier ion ratios at both 70 eV and low eV.

Powered by a unique flight-box design



Designed from first principles for optimum performance, the compact BenchTOF flight-box eliminates issues historically associated with TOF MS.

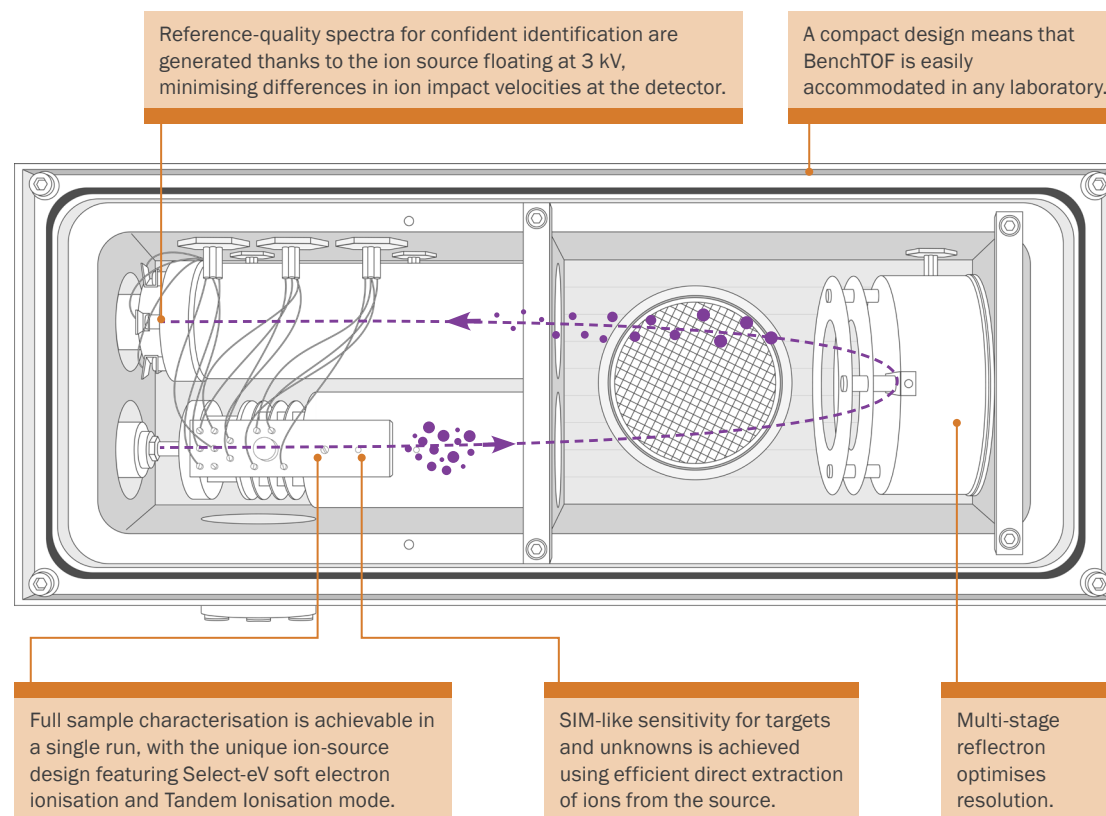

Simple integration of soft EI into laboratory workflows within TOF-DS

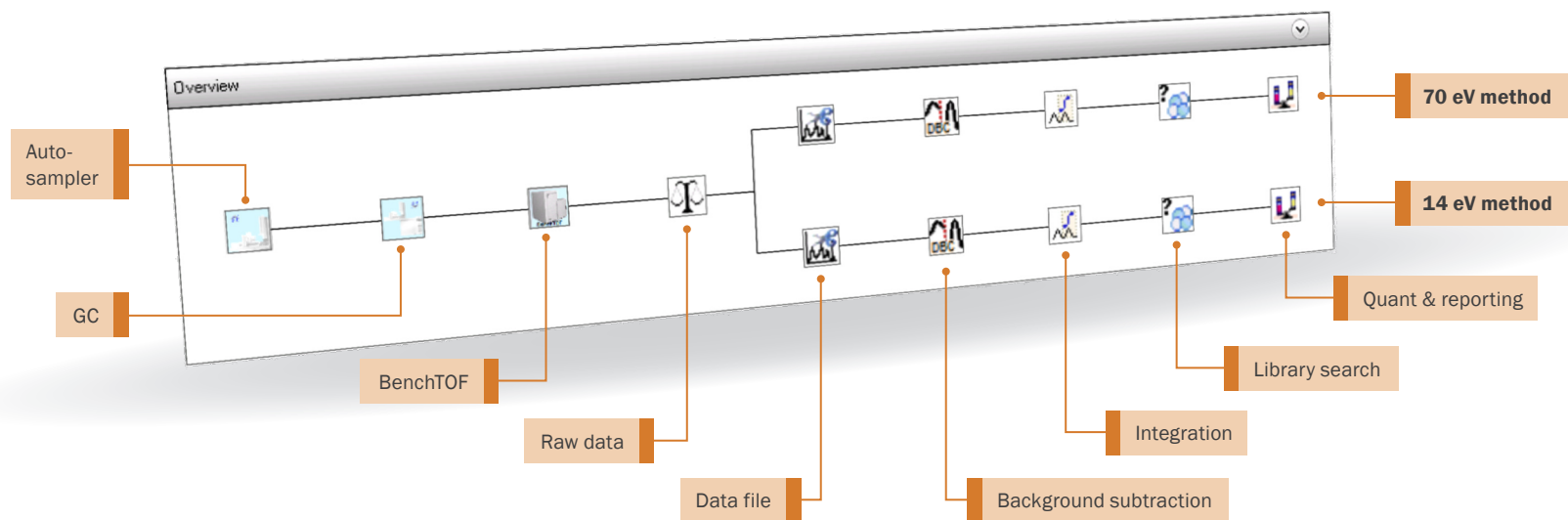

Tandem ionisation is fully integrated into the TOF-DS method workflow, with a simple graphical overview used to display each step – from instrument control all the way through to reporting of results. Here we show the use of Tandem Ionisation at 70 and 14 eV, culminating in quantitative results for both ionisation energies.

Improved detection limits with soft EI

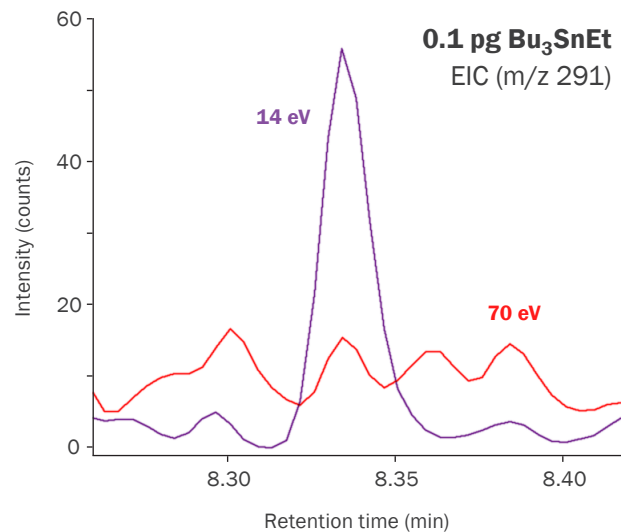
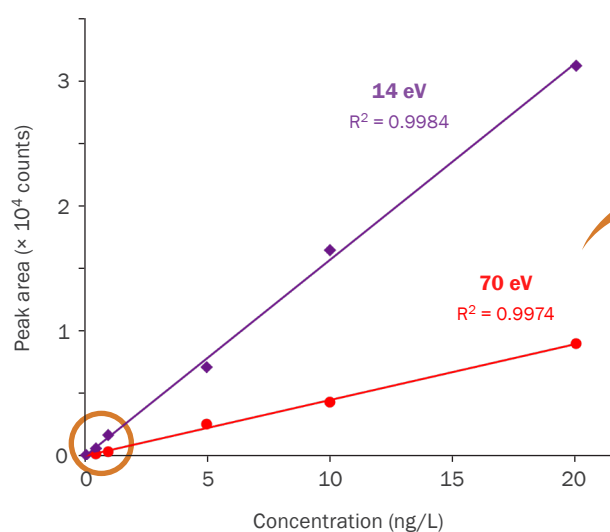

Unlike other soft ionisation techniques, the repeatability of soft EI is comparable to that of 70 eV, meaning that robust quantitation can be performed. Reduced background noise and enhanced quantitation ions also improve detection limits – as illustrated here, where the LOD achieved for a tributyl tin derivative (Bu₃SnEt) in a water extract fell from 1 pg at 70 eV, to just 0.1 pg at 14 eV.



BenchTOF-Select™

Harness the power of Tandem Ionisation for full sample characterisation in a single run.

With Tandem Ionisation, two complementary sets of spectra are continuously acquired, aiding the rapid characterisation of targets and unknowns in a single run. In addition, the robustness of BenchTOF systems allows you to use ion ratios between low-eV and 70 eV spectra as an additional qualifier for compound identification, prior to sample quantitation and reporting.

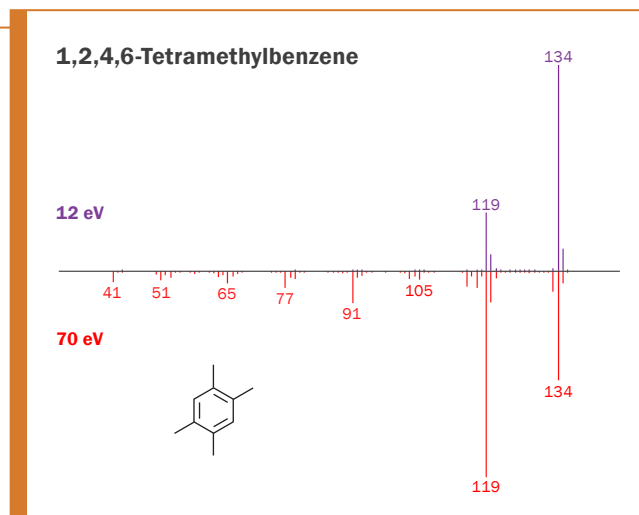
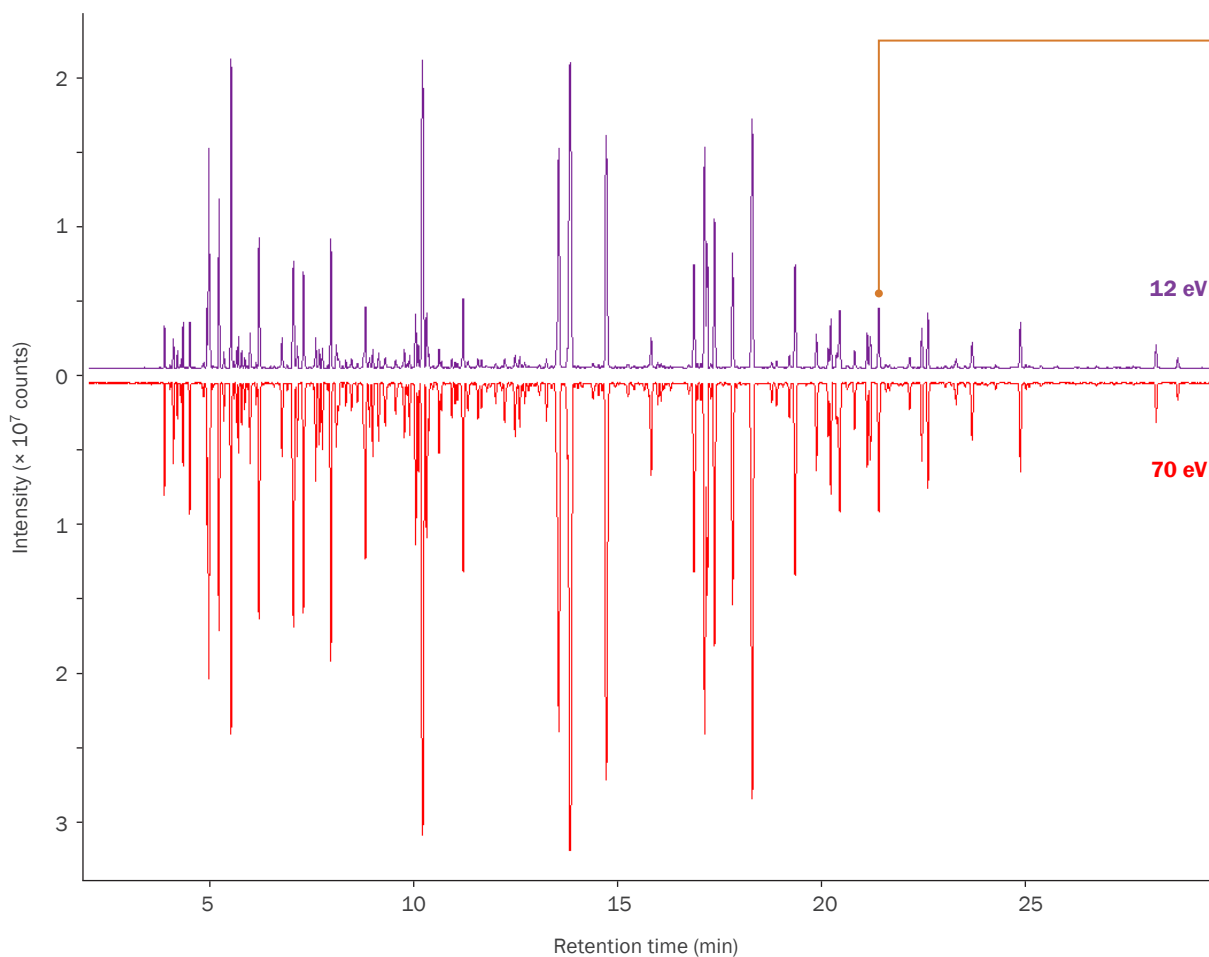

Two perfectly aligned chromatograms are generated using Tandem Ionisation, as for this example of gasoline, enabling fast exploration of hard and soft ionisation data. A library of soft ionisation spectra is provided with every BenchTOF-Select, to help rapidly integrate Tandem Ionisation into laboratory workflows.

Ultimate confidence in isomer identification

Similar terpenes in fragrance and aroma profiles can be difficult (or impossible) to speciate based on conventional 70 eV electron ionisation alone. Tandem Ionisation adds an additional level of confidence in such situations, but with no inherent loss in sensitivity, or inconvenience to the operator. It also fits seamlessly into laboratory workflows, providing independent checks of ion ratios at 70 eV and low eV, and between spectra, for robust quality control.



Speciation of isomers indistinguishable at 70 eV

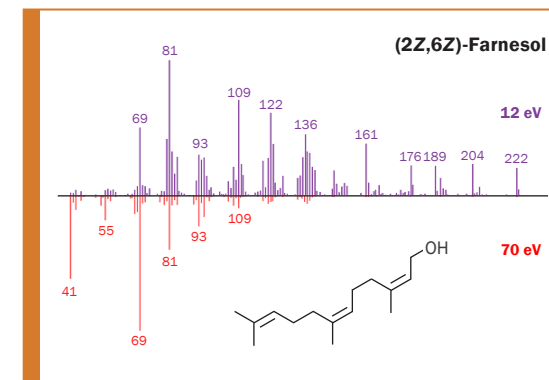
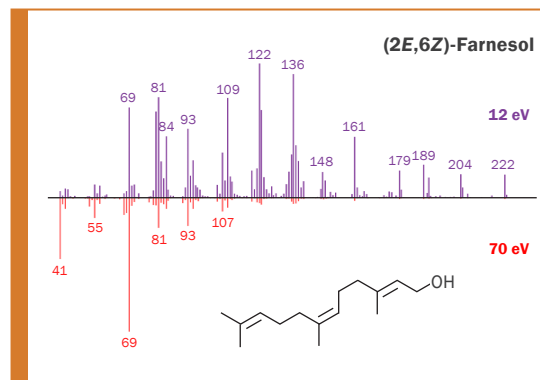
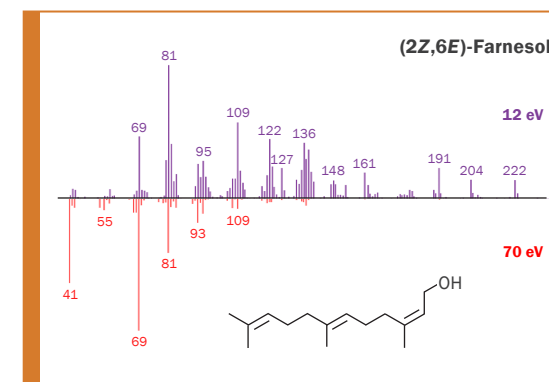
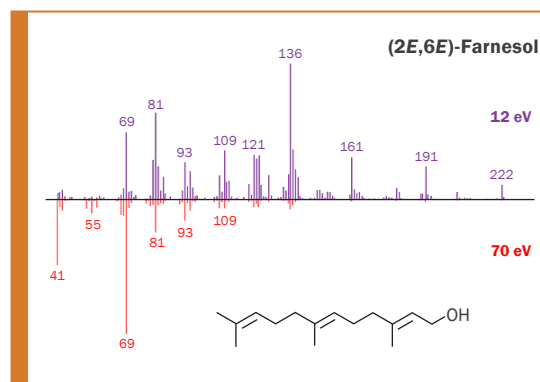
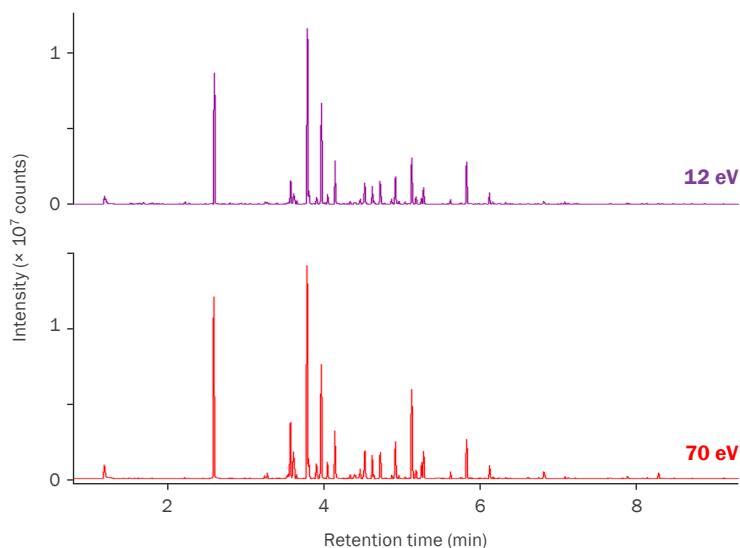

Conventional 70 eV and soft EI spectra can be acquired simultaneously in a single run using Tandem Ionisation. The result – as shown in this example of a fragranced detergent – is two complementary datasets, enabling enhanced characterisation of compounds that are impossible to speciate using just 70 eV data, such as the four isomers of farnesol.

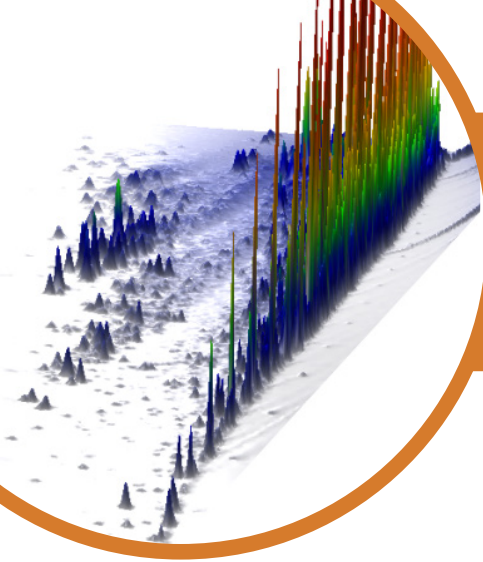

GC×GC solutions

Integrated instrument control and data processing

The new ChromSpace® software module allows you to enjoy all the benefits of TOF-DS – including full instrument control and fast method development – while also exploring and processing your GC×GC-MS files within a single software platform.

ChromSpace uses the same clean, icon-based layout as TOF-DS, further simplifying the transition to GC×GC. Key features include:

- Dynamic and targeted deconvolution modes to expose hidden peaks.
- Simplified, user-friendly quantitative workflow.
- Simultaneous acquisition and processing of MS and single-channel data, e.g. FID.
- Customisable layout to suit all users.

ChromSpace for unparalleled productivity

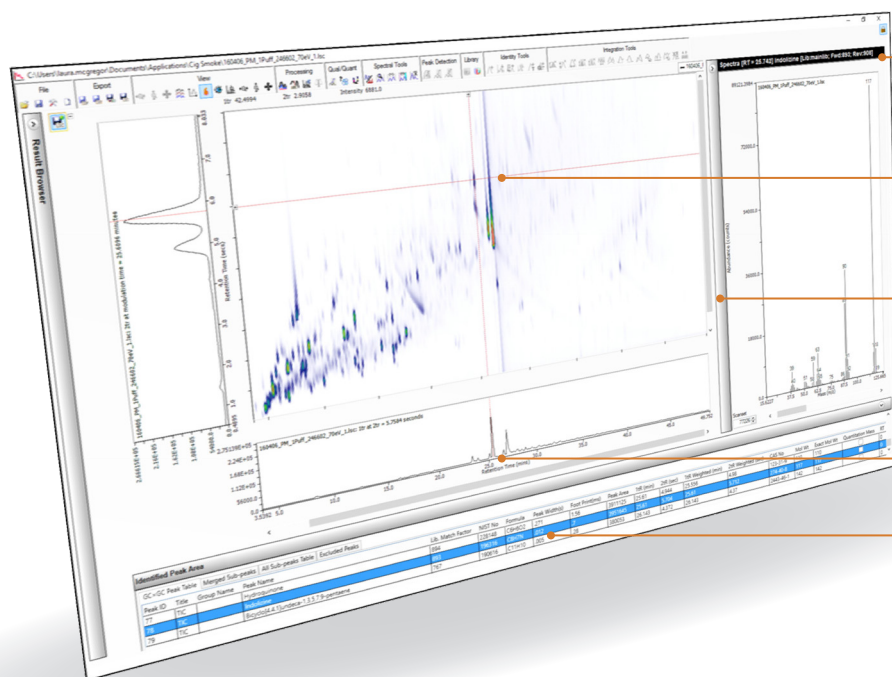

Instant library match provided when clicking on a peak.

Colour scaling immediately normalises upon zooming.

Fully customisable layout to suit all users.

Sectional plots present unfolded chromatograms in a classical format.

Peak table dynamically links chromatograms and spectrum pane for rapid data exploration.

ChromSpace is the ideal choice for exhaustive screening of complex samples. A unique combination of peak perception algorithms ensures that even trace/masked peaks are not overlooked or incorrectly merged.

Compatibility with multiple modulators

The platform-neutral design of BenchTOF means that you're not restricted to using a specific GC×GC modulator. As a result, the best modulator can be chosen for your application – with flow-modulated and thermally-modulated technologies being the most popular.

Flow modulation

- Has lower running costs.
- Enables efficient modulation of volatiles.
- Shows excellent between-sample and between-instrument repeatability.
- Can also be configured for heart-cutting two-dimensional GC.
- Allows easy implementation of parallel detection.
- May involve more complex method optimisation.

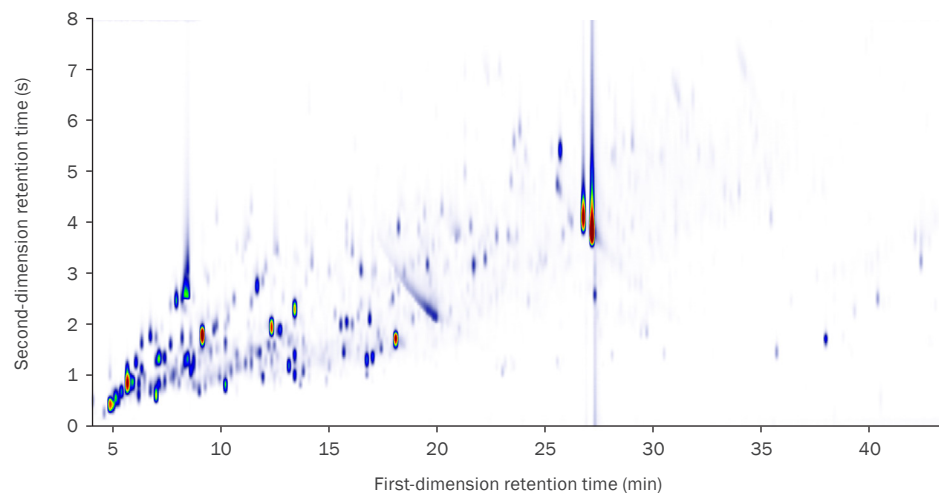

Efficient and repeatable analysis of volatiles in tobacco smoke was achieved using thermal desorption coupled with flow-modulated GC×GC-TOF MS. Optimisation of parameters revealed the complexity of this challenging whole-smoke sample, without the hassle and expense of liquid cryogen.

Thermal modulation

- Has higher running costs.
- Is the most popular modulator, with a wide user base.
- Is often restricted to analytes boiling above C₄.
- Has a high peak capacity and enhanced signal-to-noise ratios due to narrower peak widths.
- Offers simple method development.

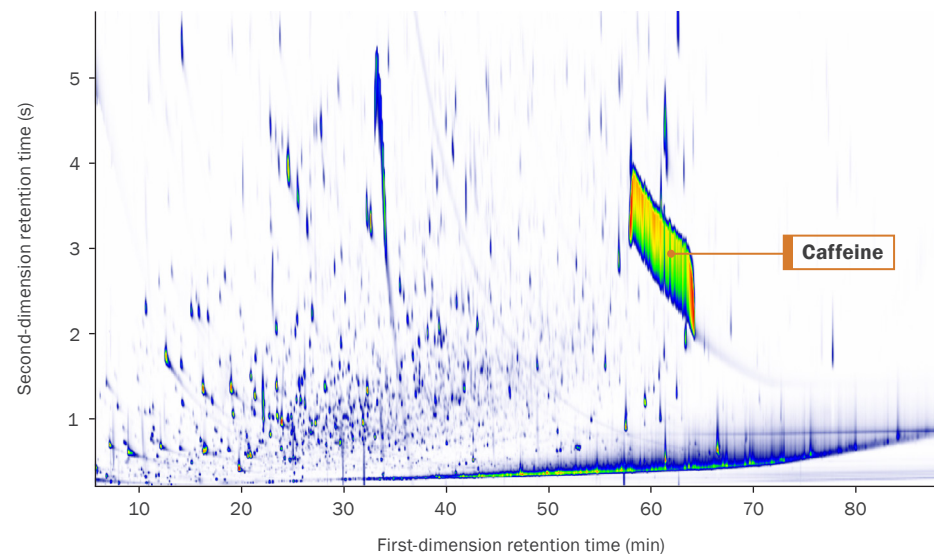

Over 3000 components were detected in this coffee extract using the high separation capacity of thermal modulation with cryofocusing, resulting in peak widths as narrow as 40 ms. Note the (predictably) high level of caffeine.

Confident screening of targets and unknowns in a single run

The combination of sensitivity, spectral quality and speed makes BenchTOF-HD, coupled with GC×GC, the perfect solution for routine GC×GC-MS work. In a single run, both targets and unknowns can be separated and confidently identified, making this technique ideal for both investigative work – such as monitoring emerging contaminants – and target-focused studies.



Comprehensive screening of environmental pollutants

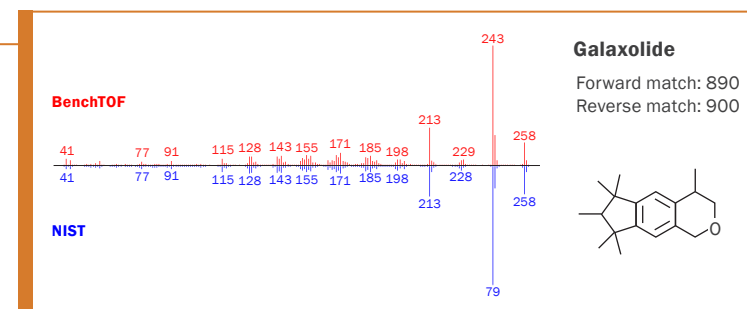
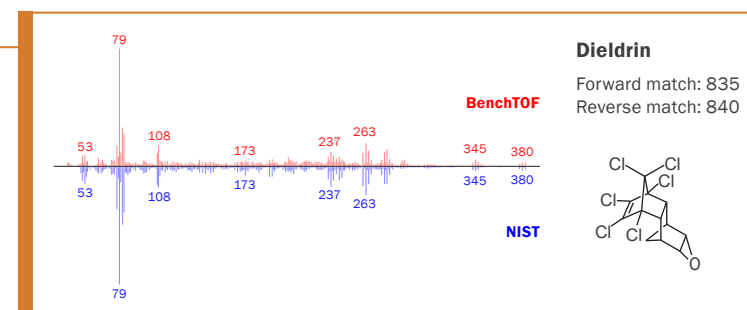
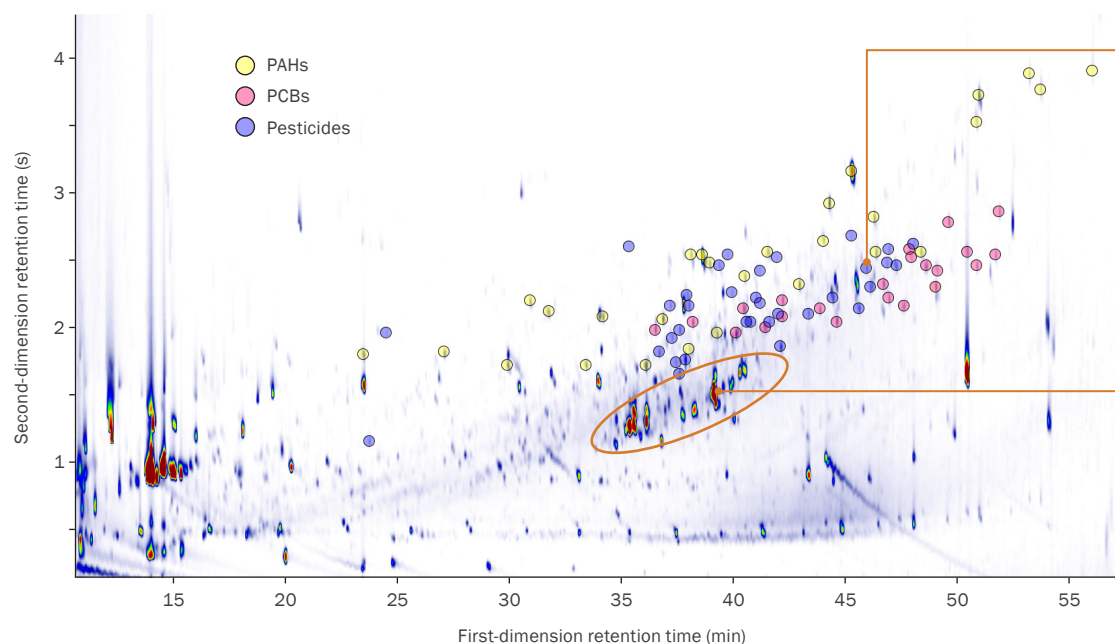

As well as identifying individual chemicals in three important groups of target compounds (PCBs, PAHs and pesticides), this entire water extract was screened for emerging contaminants, such as the polycyclic musks associated with cosmetics (circled).

Confident matching against commercial or in-house MS libraries allows fast screening of targets and 'unknowns'.

An extra dimension of information for exhaustive sample characterisation

Tandem Ionisation, by simultaneously acquiring 70 eV and soft EI spectra, complements the separating power of GC×GC – for example, by enabling in a single run the improved speciation of hydrocarbon isomers that is crucial for robust chemical fingerprinting. Alongside this is the outstanding analytical resolution required to tackle even the most complex petrochemicals, courtesy of the speed, sensitivity and the unique soft electron-ionisation capability of BenchTOF-Select.



Additional confidence in chemical fingerprinting

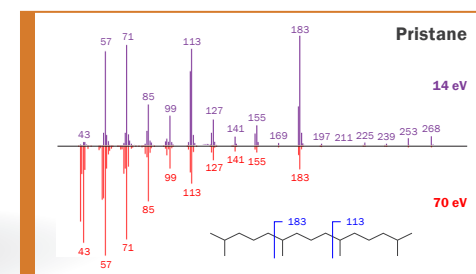
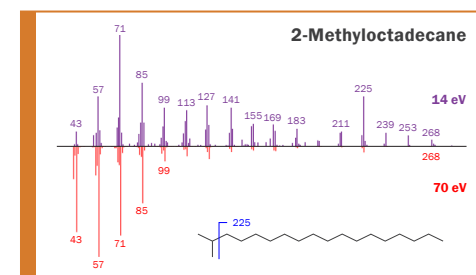
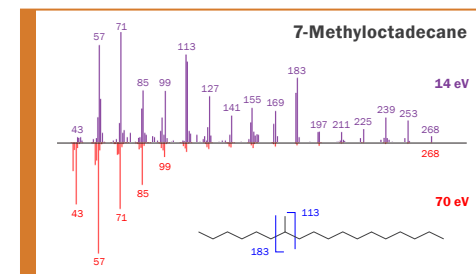
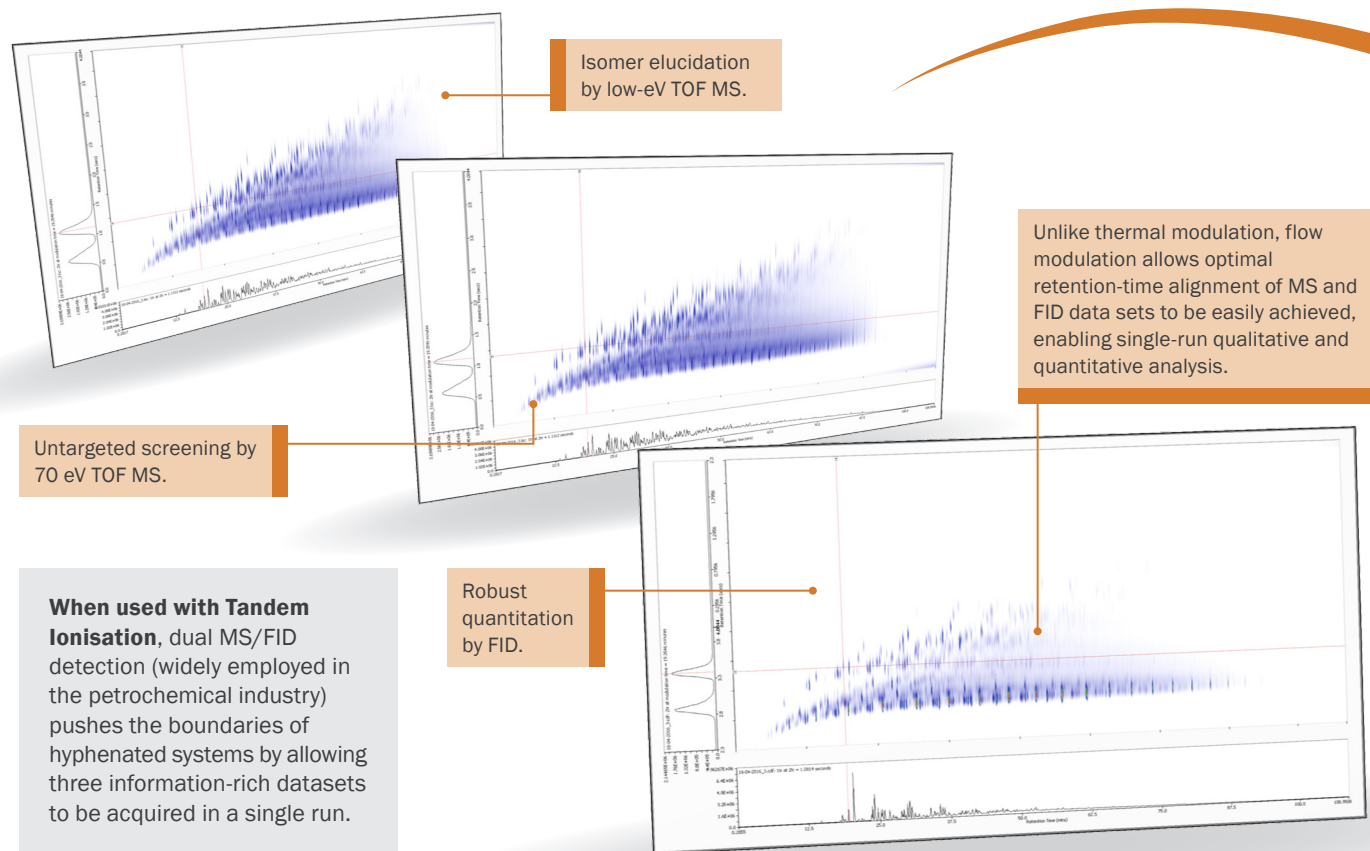

Since 1997



Markes International

UK: Gwaun Elai Medi-Science Campus, Llantrisant, RCT, CF72 8XL **T:** +44 (0)1443 230935
USA: 2355 Gold Meadow Way, Gold River, Sacramento, California 95670 **T:** +1 866-483-5684 (toll-free)
Germany: Bieberer Straße 1-7, 63065 Offenbach am Main **T:** +49 (0)69 6681089-10
P.R. China: No. 1 Building, No. 7 Guiqing Road, Xuhui District, Shanghai 200233 **T:** +86 21 5465 1216
E: enquiries@markes.com **W:** www.markes.com

